

Thermal Printer 312 Series

3X012CX 3-Inches With Cutter

Product Features

- 3 Inches Thermal Printer With Cutter
- Thermal Printing Method
- Dots/line 640 dots/line
- Printing Width (mm) $80 \pm 0.2\text{mm}$
- Paper Width (mm) Max. 82.5mm (3.24 inch)
- Paper Thickness 60 to 180 μm
- Easy Paper Loading
- Support Paper Near-End Sensor (Option)
- Support Cutter
- Support Wide Operating Voltage Range



Product Specification

Printer

- Print Method :Thermal line dot printing
- Printing Speed :Max. 100mm/second
- Number of dots/line: 640 dots
- Print Resolution: 8mm (dots/mm)
- Printing Width: 80 ± 0.2mm
- Paper Width: Max. 82.5mm(3.24inch)
- Printing Thickness : 60 to 180 μ m
- Paper Roller Diameter : Max. 100mm
- Print Color : Black

Power Supply (V)

- Operating Voltage:12V (± 10%)
- Printer Head : 12V ± 10% (DCV)
- Stepping Motor : 12V to 24V (DCV)
- Cutter DC Motor : 12V
- Head Logic : 3V to 5.5V (DCV)
- Head Heat Element : 12V(Type)
18V (Max.)
- Energy Consumption : 0.8mJ/dot
(0.5ms/line, 25°C)
- Power Consumption : 0.41W/dot

Life

- TPH Life : Pulse Life: 1x 10⁸ pulses
- Abrasion Life : 100km (Printer
area 12.5%)
- Cutter Life : 1000000 times(Based
On 0.1mm Ordinary Paper)

Paper Cutter

- Type : Slide Type (Easy Loading)
- Cutting Width (mm) : 82.5mm (Max.)
- Cutting Thickness (mm) :
Max. 0.18mm
- Min. Cut Length (mm) : 10 mm
- Cutting Type : Full Cuts

Detection

- TPH Temperature : Thermistor
- Platen Position : Photo Interrupter
- Out Of Paper : Photo Interrupter
- Cutter Home Position : Micro Switch

Additional Features

- Paper Near-end Sensor Option
Available

Product Specification

Environment

- Operating temperature: 5°C ~ 40°C
(No Condensation)
- Operation Humidity : 20~60RH
(No Condensation)
- Storage Temperature: -20°C ~ 60°C
(Excluding Paper)

Fonts

- ISO 8859
- ISO 8859-2
- Traditional Chinese (Big-5)

Interface

- RS232
- USB

Dimensions

- 113mm(L) x 34.5mm(W) x 51mm(H)

OS Support

- Windows 2000
- Windows XP
- Windows 7
- Linux Drivers

Certificate

- RoHS
- FCC Class B
- ESD Level 2

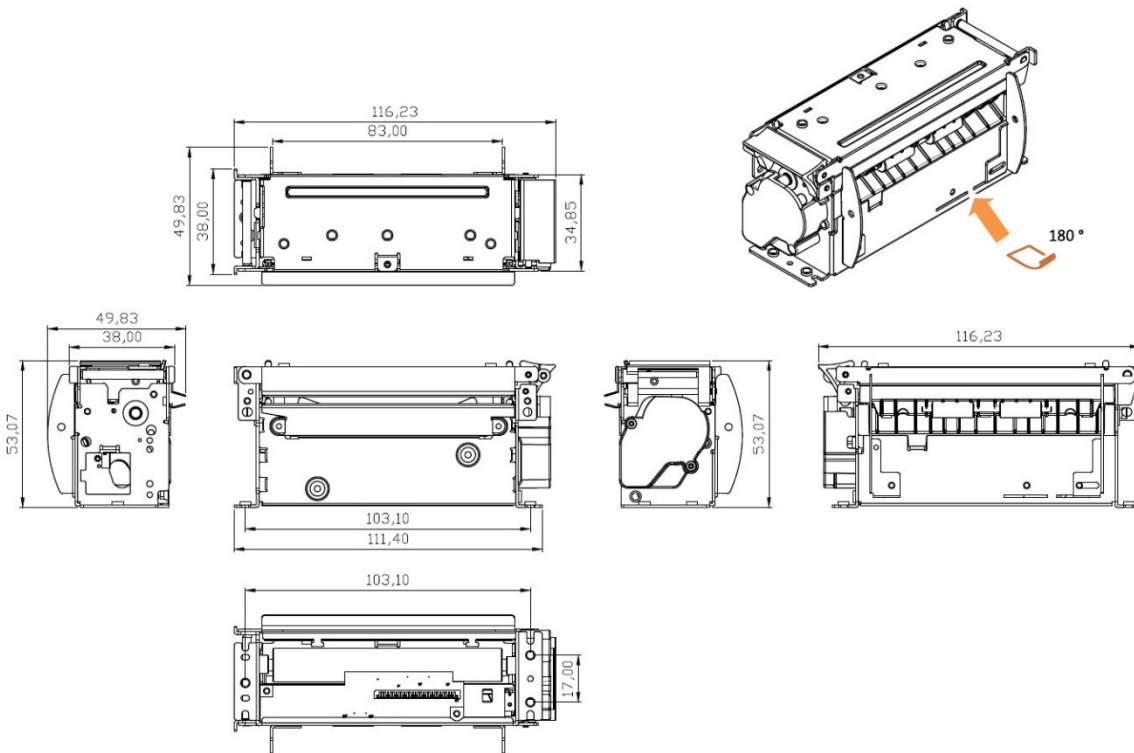

Product Introduction

The 312 Series is a 3 inch thermal printer head, with cutter for paper cutting. It is a high speed, high reliability, high performance thermal printer module, printing on 80mm width thermal paper. Its printing speed is up to 100mm/s, with voltage supply 12V and provide paper near-end sensor option. Thermal printers print more quietly and usually faster than impact dot matrix printers. They are also smaller, lighter and consume less power, making them ideal for portable and retail applications. The 312 series thermal printer module can be found in customer terminals, POS printer, ticket issuing terminals, barcode printers, banking terminals, cash register devices, and can be embedded easily into system or applications which require print outs.



Tel : +886-2-2218-8082 Ext.815 / 816 E-mail : info@jarltech.com.tw
 Add : 3F., No.1, Ln. 538, Zhongzheng Rd., Xindian Dist., New Taipei City 23141, Taiwan
www.jarltech.com.tw

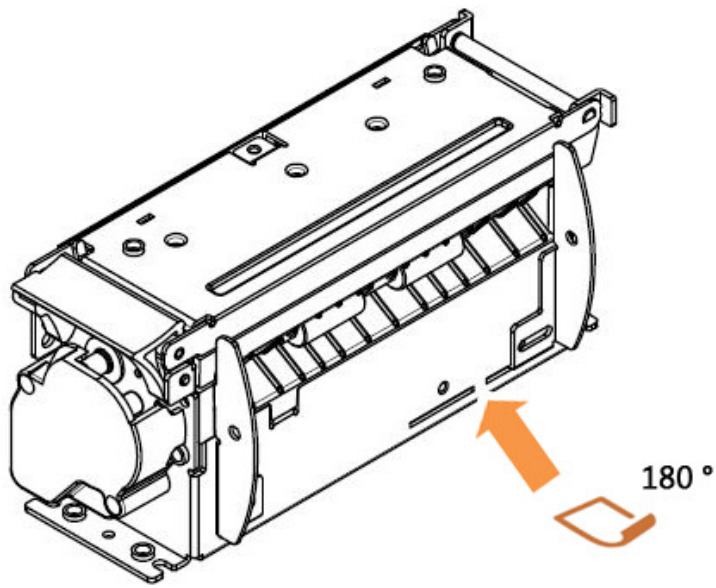

Product Introduction

The 312 series feed angel is 180 degrees, different from other providers. Thermal printers are well known for their high printing speed, which make some very suitable for some business applications. They do not have a lot of moving parts, therefore they are extremely reliable. Additionally, they have images that are durable, particularly thermal transfer printers.